

# SR770

(Code: G565)

## For Machine Code: G060 / G080/ G082/ G106 INSTALLATION GUIDE

### ⚠ Caution

- Before installing options, the machine should be turned off and unplugged for at least thirty minutes. Components inside the machine become very hot, and could result in a burn if touched.
- When lifting the machine, use the grips on both sides. The machine could break or cause injury if dropped.
- It is dangerous to handle the plug with wet hands. Doing this may result in receiving an electric shock.
- Before moving the machine, unplug the power cord from the outlet. If the cord is unplugged abruptly, it could become damaged. Damaged plugs or cords can cause an electrical or fire hazard.
- When moving the 2 tray finisher, hold the center of both sides, and lift slowly. Lifting carelessly or dropping it may cause injury.

### 🔦 Important

- Check the printer nameplate to confirm the model code.
- Install the paper feed unit before installing the 2 tray finisher.
- Install the memory unit options before attaching the 2 tray finisher.
- You cannot install the 2 tray finisher unless both the paper feed unit and duplex unit with options are installed.
- The 2 tray finisher requires the optional printer hard disk or optional memory unit of total 128 MB.
- You cannot install the 4-bin mailbox and 2 tray finisher at the same time.

### 📝 Note

- The 2 tray finisher weighs approximately 53kg (116.9 lbs).

## 1 Check the contents of the box:

Description	Qty
Finisher	1
Short Screws	2
Long Screws	6
Connecting Bracket	1
Mounting Bracket	1
Rail	1
2 Tray Finisher Trays	2
Installation Guide(This sheet)	1

## 2 Be sure to check the following points:

- The power is turned off.
- The power cord is unplugged from the wall outlet.
- The interface cable is unplugged from the printer.

## 3 Remove the adhesive tape and packing materials.

### 📝 Note

- Do not remove the adhesive tape holding the cable yet. Remove it in step 20.

### Front and Side

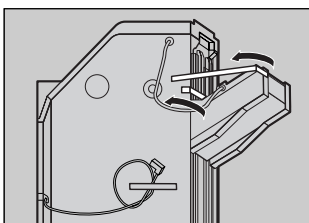
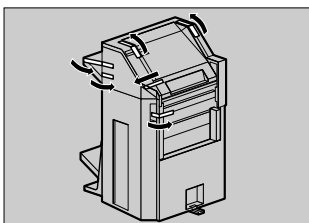

### Back

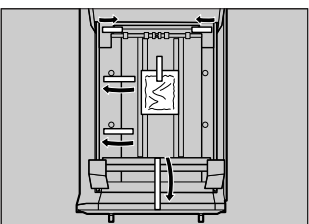
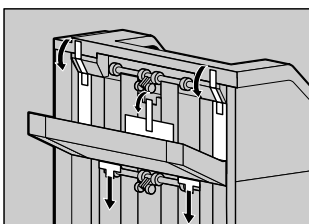

### Interior

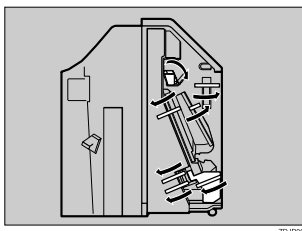

## 4 Slowly open the front cover by pulling on the two areas on the left and right.

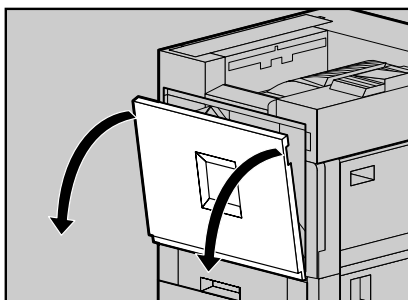

## 5 Remove the green screwdriver, and then close the front cover.

Use this screwdriver for all attachment and detachment of screws.

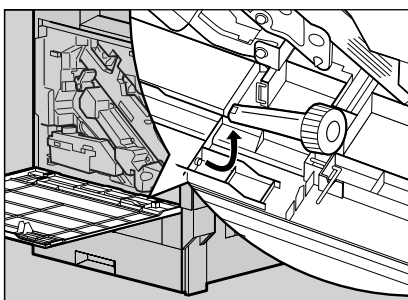

### 📝 Note

- After using the screwdriver, return it to its original position on the inside of the front cover.

6

Stand the external tray of the printer.

1 Stand it vertically.

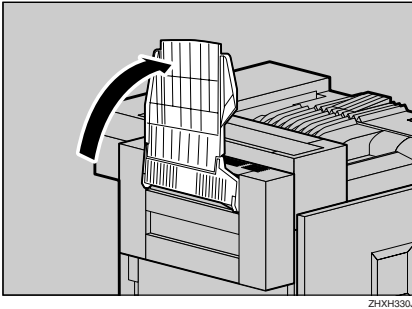

ZHXH330J

2 Fold it over the top of the printer.

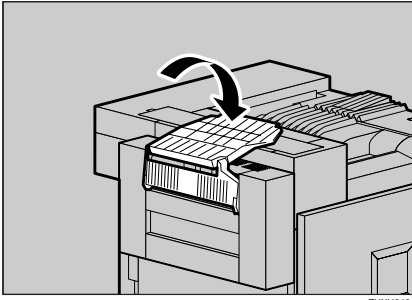

ZHXH340J

7

Insert the rail with a wheel in the mounting bracket.

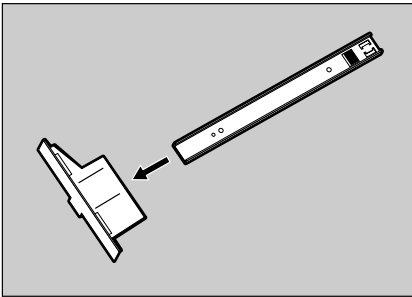

ZDJP066J

8

Temporarily fasten one long screw in the position, as shown. Turn the screw three to four times by hand.

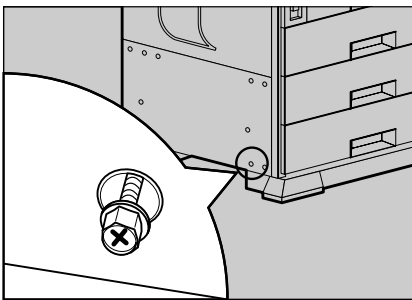

ZDJP067J

9

Insert the rail, assembled in step 7, into the base area under the printer.

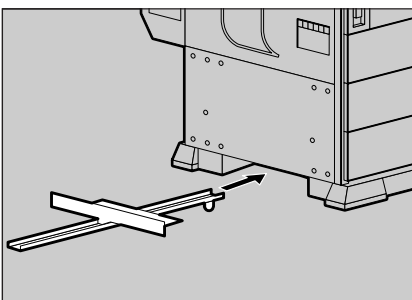

ZDJP068J

10

Hook the hole of the mounting bracket on the screw temporarily fastened in step 8.

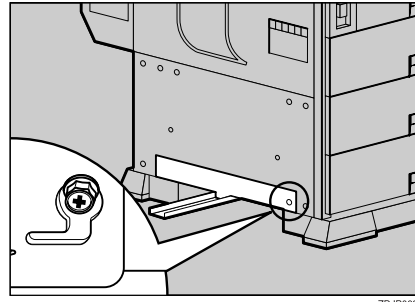

ZDJP069J

11

Holding the mounting bracket using both hands, move it in the direction of up (1) to the right (2).

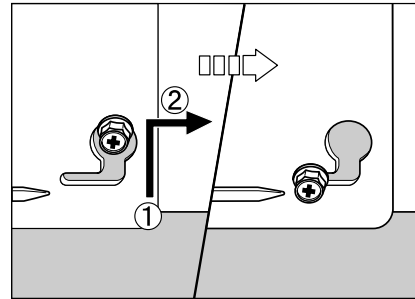

ZDJP070J

12

With the left corner of the mounting bracket in the position pointed by the arrow on the printer, fasten the left side of the mounting bracket using a long screw and the provided screwdriver. Also tighten the screw on the right side temporarily fastened in step 8.

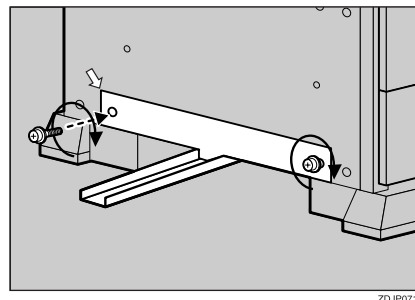

ZDJP071J

13

Temporarily fasten the two long screws in the positions shown. Turn the screws three to four times by hand.

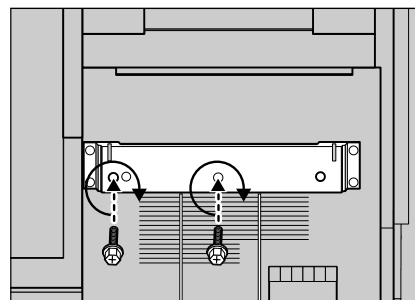

ZDJP072J



- 14** Hook the connecting bracket onto the screws temporarily tightened in step 13.

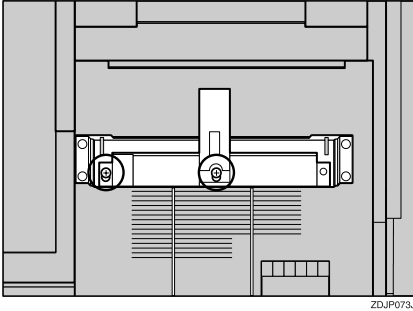

- 15** Fasten the right side of the connecting bracket using a long screw and the provided screwdriver. Also tighten the two screws temporarily tightened in step 13.

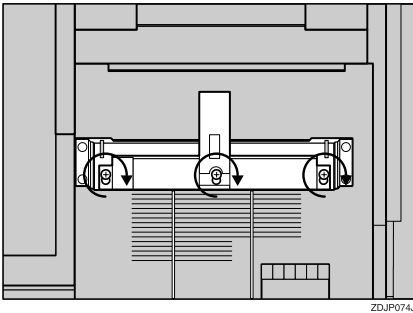

**Note**

- If you have the 1000-sheet paper feed unit or 2000-sheet Large Capacity Tray installed, proceed to step 17.

- 16** If you have the 500-sheet paper feed unit installed, change the position of the connecting bracket on the side of the 2 tray finisher to the lower level. Remove the two screws using the provided screwdriver, then move the connecting bracket down, and then refasten the screws.

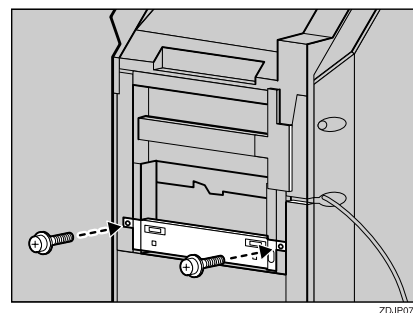
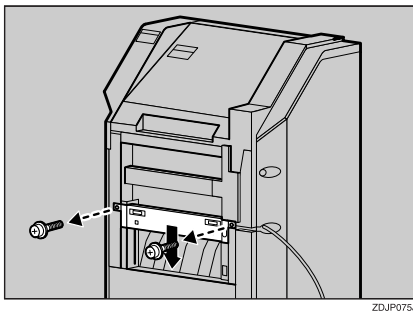

- 17** Place the printer's trail on the 2 tray finisher, and then slide until it stops.

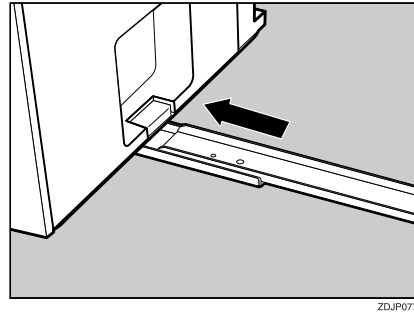

- 18** Fasten the rails using a long screw provided screwdriver.

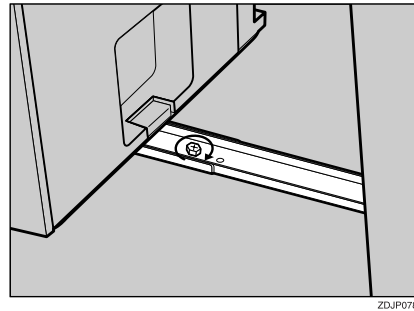

- 19** Slowly push the 2 tray finisher toward the printer until it stops.

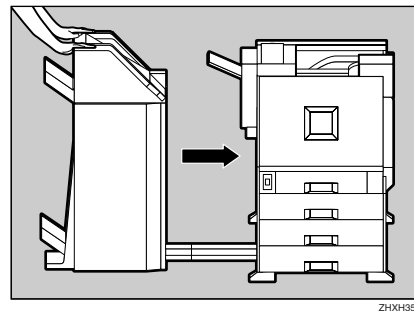

- 20** Remove the tape fastening the cable to the 2 tray finisher.

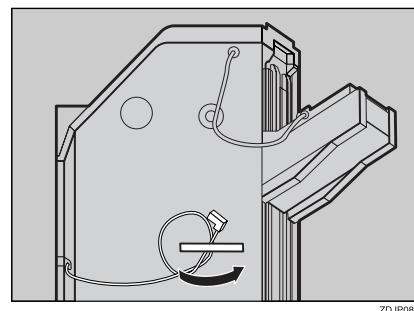

21

Connect the cable of the 2 tray finisher to the lower connector on the back of the printer.

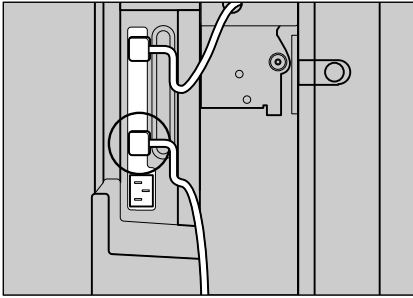

ZDJP081J

22

Place the two 2 tray finisher trays in the 2 tray finisher.

**Note**

The two finisher trays are identical.

- 1 Adjust the notch on the left side of the 2 tray finisher tray to the cable coming out from the 2 tray finisher.

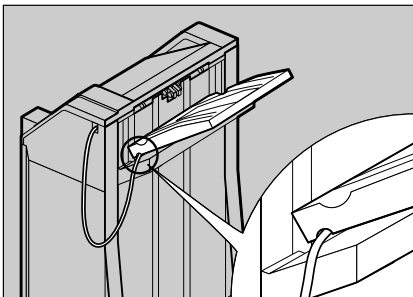

ZDJP082J

This step is unnecessary if you are using the lower area.

- 2 With the 2 tray finisher tray laid horizontally, slide it in at a slant until it stops.

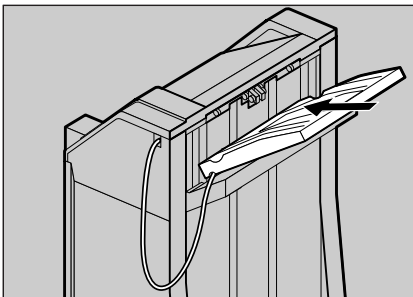

ZDJP083J

- 3 Fasten the finisher tray using a short screw and the provided screwdriver.

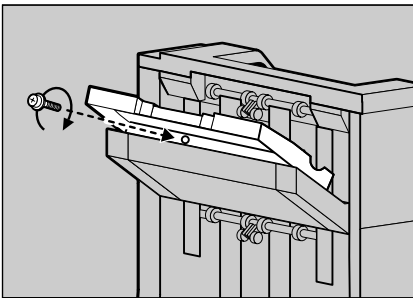

ZDJP084J

- 4 Use the same steps (2) and (3) to install the other 2 tray finisher trays.

23

Be sure to return the provided screwdriver to its original position on the inside of the front cover.

24

Put the finisher tray installed on the duplex unit back in place.

- 1 Lift the top.

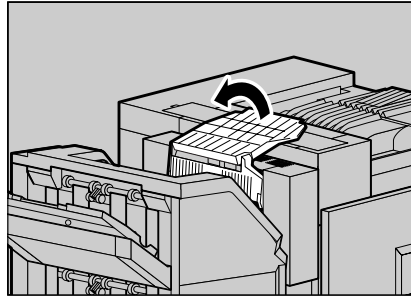

ZHXX360J

- 2 Lower slowly.

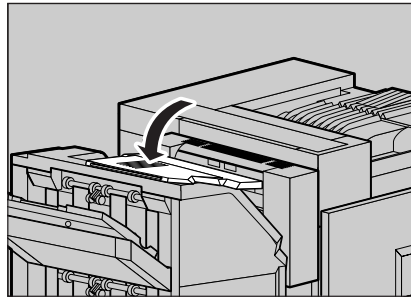

ZHXX370J

**Note**

- After finishing the installation, you can check the finisher is installed properly: Print the configuration page from the "List/Test Print" menu. If it is installed properly, you will see "2 Tray Finisher" appear in the "Options" list. (G060, G080, G106)
- After finishing the installation, you can check the finisher is installed properly: Print the configuration page from the "Print Menu" menu. If it is installed properly, you will see "Finisher: Installed" appear in the "Installed Options" list. (G082)
- If the finisher is not installed properly, repeat the procedure from step 1. If you cannot install it properly even after reinstallation, contact your sales or service representative.